



**PRAIRIELAND ENERGY, INC**

**REQUEST FOR ELECTRICITY FROM ON-SITE SOLAR FARM  
2.0 AND PPA PROPOSAL**

**For**

**The University of Illinois at Urbana-Champaign**

**Issued February 25, 2019**

---

**Proposals must be received before  
2:00 PM CST Wednesday April 3, 2019**

**Send proposals to:**

**PrairieLand Energy, Inc.**

**Attn: Kevin Chalmers**

**[kchalmer@uillinois.edu](mailto:kchalmer@uillinois.edu)**

**Phone: (217) 244-3678**



## CONTENTS

OVERVIEW AND ASSURANCES.....	3
EVALUATION AND AWARD OF CONTRACT .....	11
SPECIFICATIONS OF PPA.....	13
LOCATION.....	13
PHOTOVOLTAIC SYSTEM.....	14
EQUIPMENT AND SUPERVISION REQUIRED .....	16
OPERATIONS AND MAINTENANCE .....	16
ACCESS ROADS.....	17
PERMITTING.....	18
RENEWABLE ENERGY INCENTIVES.....	18
REQUIRED SUBMITTALS .....	18
SHOP DRAWINGS .....	18
PRE-JOB MEETING .....	19
PREVAILING WAGE .....	19
COORDINATION.....	19
PROPOSAL RESPONSE .....	20
PART 1: TECHNICAL PROPOSAL .....	21
PART 2: PRICING PROPOSAL .....	23
APPENDIX A: Pricing Information .....	
APPENDIX B: Plat of Survey/Topographic Survey.....	
APPENDIX C: Utility Program Statement .....	

## **OVERVIEW AND ASSURANCES**

### **BACKGROUND**

PrairieLand Energy, Inc. (PEI) is an Illinois corporation formed in 1996. PEI is solely owned by the Board of Trustees of the University of Illinois and functions as a University Related Organization. PEI's primary mission is to provide energy commodities to the University of Illinois at Urbana-Champaign, Chicago, and Springfield, as well as regional campuses in Peoria and Rockford, Illinois. PEI procures energy commodities (primarily electricity and natural gas), which is subsequently resold to the Universities and regional campuses for their consumption. PEI also provides retail energy services to a small number of non-University customers located on University distribution systems.

PEI is seeking Proposals from qualified firms ("Proposers") to design, build, operate, and maintain a Solar Farm at the University of Illinois at Urbana-Champaign, with a corresponding twenty (20) year Power Purchase Agreement (PPA). Proposers should also provide alternative costs for a ten (10) year PPA.

Proposers should provide three fixed-price bids in the form of dollars per megawatt-hour (\$/MWh):

- (1) delivered on site solar farm energy with no Solar Renewable Energy Certificates (RECs) included in PPA,
- (2) delivered on site solar farm energy bundled with and including the associated Solar RECs generated on this site, and
- (3) delivered on site solar farm energy that includes alternative REC swaps in an equal quantity as generated on site.

The Proposer shall have demonstrable experience installing and servicing Solar Farms. The Proposer or selected contractor shall install, operate, and maintain the equipment with competent and experienced workmen. The solar panels shall be manufactured and supplied by a company regularly engaged in the business of furnishing solar electrical generating system.

The University requests a time frame with proposal when design and installation work will be started and completed for consideration towards award of proposal. Proposers shall provide a minimum of thirty days notice prior to on-site mobilization at the beginning of the project. Work shall be performed during standard industry hours and in compliance with all holidays.

The University prefers the construction of the Solar Farm to begin before the end of calendar year 2019, but **mobilization on-site is restricted until October 1, 2019**, which is when the harvest will be completed.

**Proposer Responsibility:** In no way shall the Proposer/manufacturer/contractor be relieved of the primary responsibility to provide a safe, code compliant, fully functional system.

**Codes and Standards Compliance:** The University will only consider proposals from Proposers who demonstrate that their units are sited in an environmentally responsible manner and in compliance with applicable local, state and federal laws and regulations.

## **ENERGY COMMODITIES AND PPA REQUIRED**

The PPA pricing must be inclusive of all development, engineering, construction, operations, and maintenance costs associated with the project for the term of the agreement, with the requirement that no costs will accrue to PEI beyond the proposed purchase price per MWh, except for the amount of the contract buyout as detailed below. Proposers must also provide a schedule of termination values for each year prior to the expiration of the PPA.

Proposals must also indicate whether there is an early buy-out option, at Fair Market Value (FMV). Proposers should also indicate whether they intend to donate the system in years six, ten, or fifteen of the agreement, or at the end of term. At the end of the contract period, the University requires right of first refusal to purchase the solar assets at FMV. Proposers should provide a draft PPA, and specify their typical FMV calculation methodology. PEI currently defines FMV as follows:

“Fair Market Value” of the System shall be the value determined by the mutual agreement of PEI and Proposer within ten (10) days after receipt by Proposer of PEI's notice of its election to purchase the System. If PEI and Proposer cannot mutually agree to a Fair Market Value, then the Parties shall select a nationally recognized independent appraiser with experience and expertise in the solar photovoltaic industry to value such equipment. Such appraiser shall act reasonably and in good faith to determine the Fair Market Value and shall set forth such determination in a written opinion delivered to the Parties. The valuation made by the appraiser shall be binding on the Parties in the absence of fraud or manifest error. The costs of the appraisal shall be borne by the Parties equally. To the extent transferable, the remaining period, if any, on all warranties for the System will be transferred from Proposer to PEI at PEI's sole expense. If the Parties are unable to agree on the selection of an appraiser, such appraiser shall be jointly selected by the appraiser firm proposed by PEI and the appraiser firm proposed by the Proposer.”

1. Complete **Appendix A: Pricing Information**, including:
  - a. Pricing for Bid (1), Bid (2) and Bid (3) per each bid description, see below.
  - b. Provide a schedule of buyout options for years 6, 10, and 15.
  - c. Indicate availability of donation options for years 6, 10, 15, and 20.
  - d. Provide a schedule of termination values for each year of the term.
2. Available state and federal incentives should be pursued by the Proposer, and the related PPA price should reflect those incentives.
3. The University of Illinois will lease the land to the selected Proposer for \$1.00 per year, through a Land Lease Agreement for the duration of the PPA.
4. Bids for PPA pricing proposals must be defined as dollars per megawatt-hour (\$/MWh) of electricity delivered, with no escalation rate.
5. RECs included in Bids 2 or 3 must be transferred by Proposer to PEI using the Midwest Renewable Energy Tracking System (M-RETS) on behalf of the University of Illinois.
6. Submission must include details of how the price per MWh was arrived at, including projected Engineering, Procurement, and Construction (EPC) costs, depreciation, investment tax credits, sale of RECs, operating revenue and costs, and projected profit.

### **Bid 1 – Delivered Energy produced On-Site (Solar Farm 2.0)**

- PrairieLand Energy Inc. will purchase each MWh of energy produced, and the Proposer may retain the environmental attributes (RECs) associated with each MWh produced at the on-site Solar Farm 2.0.

### **Bid 2 – Delivered Energy and attributes (RECs) produced On-Site (Solar Farm 2.0)**

- PrairieLand Energy Inc. will purchase each MWh of energy produced, and the environmental attributes (RECs) associated with each MWh produced at the on-site Solar Farm 2.0.



- The Proposer awarded the winning RFP bid, will be responsible for creating and transferring the REC certificates to PEI using the Midwest Renewable Energy Tracking System (M-RETS)

**Bid 3 – Delivered Energy produced On-Site (Solar Farm 2.0) with alternative renewable attributes (RECs)**

- Prairieland Energy Inc. will purchase each MWh of energy produced. The Proposer may retain the environmental attributes (RECs) associated with each MWh produced at the on-site Solar Farm 2.0.
- The Proposer will provide an alternative (REC) (for example, wind RECs) for PEI for each MWh of energy generated on-site. The Proposer awarded the winning RFP bid, will be responsible for transferring the RECs to PEI using the Midwest Renewable Energy Tracking System (M-RETS).

**SCHEDULE**

All times listed are Central Time (CST). The following schedule is subject to change:

Issuance of RFP		Monday	February 25, 2019
RSVP for Conference	2:00 P.M.	Wednesday	March 13, 2019
Pre-Proposal Conference	3:30 P.M.	Thursday	March 14, 2019
Deadline for RFP Questions	5:00 P.M.	Thursday	March 21, 2019
Distribution of Q&A		Thursday	March 28, 2019
Proposal Due Date	2:00 P.M.	Wednesday	April 3, 2019
Anticipated Selection of Vendor(s)			April 19, 2019
Anticipated Award of Contract			August 1, 2019
Construction Mobilization Allowed			October 1, 2019
Anticipated Project Completion			Summer 2020



## **PRE-PROPOSAL CONFERENCE**

PEI will hold a pre-proposal conference to answer any questions regarding the services requested or proposal procedures. Multiple representatives from each proposer team may attend the pre-proposal conference. Attending the Pre-Proposal conference is optional, but strongly encouraged. All cost directly incurred by proposer to attend pre-proposal conference is solely the responsibility of each individual proposer.

Please RSVP to Kevin Chalmers at [kchalmer@uillinois.edu](mailto:kchalmer@uillinois.edu) no later than **2:00 P.M. on Wednesday, March 13, 2019.**

The Pre-Proposal Conference will be held on March 14, 2019 at 3:30 P.M. at:

Facilities & Services  
Physical Plant Services Building  
Conference Room 1810  
1501 S. Oak Street  
Champaign, IL 61820

After the meeting, Proposers are invited to visit the site and carefully examine the area to familiarize themselves with the existing conditions and satisfy themselves as to the nature and scope of the work to be done and the difficulties that attend its execution. The submission of a quotation will be construed as evidence that such an examination has been made and later claims for labor, equipment, or materials, of any kind, required for difficulties encountered which could have been foreseen had such an examination been made, will not be recognized.

## **RFP QUESTIONS**

PEI will answer questions regarding the energy commodities requested or proposal procedures by individual request via email. Prospective respondents must submit their questions by email no later than 5:00 P.M., CST, Friday, March 21, 2019, to Kevin Chalmers at [kchalmer@uillinois.edu](mailto:kchalmer@uillinois.edu). Questions submitted by any other means will not be included in the Q&A responses to be distributed on March 28, 2019.

## **PROPOSAL MATERIALS**

Any material submitted in response to this RFP becomes the property of PEI upon delivery.

## **AMENDMENTS TO RFP**

PEI may make amendments to this RFP prior to the Proposal opening date. If PEI determines that amendments are necessary for clarification or other purposes, all potential Respondents will be notified in a timely manner. Amendments may include an Amendment Acknowledgment section that must be signed by an authorized Respondent representative and returned with the Proposal on or before the Proposal opening date. Failure to sign and return any and all amendment acknowledgments may be grounds for rejection of the Proposal response.

## **PROPOSAL MODIFICATION**

Proposals submitted prior to the Proposal Due Date may be modified or withdrawn only by written notice to PEI. Such notice must be received by PEI prior to the Proposal Due Date. Proposer may change or withdraw the Proposal at any time prior to the Proposal Due Date; however, no oral modifications will be allowed. Only letters or other formal written requests for modifications or corrections of a previously submitted Proposal that are addressed in the same manner as the Proposal and that are received prior to the Proposal Due Date will be accepted. The Proposal, when opened, will then be corrected in accordance with such written requests, provided that the written request is contained in a sealed envelope that is clearly marked as "Modification of Proposal." No modifications of the Proposal will be accepted at any time after the Proposal Due Date. A withdrawn Proposal may be resubmitted up to the time designated for the receipt of Proposal provided that it is then fully in conformance with the requirements of the RFP.

## **PROPOSER'S RESPONSIBILITY TO READ RFP**

The Proposer must thoroughly examine and will be held to have thoroughly examined and read this entire RFP document. Failure of Proposers to acquaint themselves fully with existing conditions or the amount of work involved will not be a basis for requesting extra compensation after the award of a Contract.

## **ERRORS AND OMISSIONS**

The Proposer is expected to comply with the true intent of this RFP taken as a whole and shall not avail itself of any errors or omissions to the detriment of the services. Should the Proposer suspect any error, omission, or discrepancy in the specifications or instructions, the Proposer shall



immediately notify PEI, in writing, and PEI shall issue written instructions to be followed. The Proposer is responsible for the contents of its Proposal and for satisfying the requirements set forth in the RFP.

## **ALTERATION/MODIFICATION OF ORIGINAL DOCUMENTS**

The Proposer certifies that no alterations or modifications may be made to the original content of this RFP or other procurement documents (either text or graphics and whether transmitted electronically or hard copy). Any alternates or exceptions (whether to products, services, terms, conditions, or other procurement document subject matter) must be apparent and clearly noted in the offered response. Proposer understands that failure to comply with this requirement may result in the offer being disqualified and, if determined to be a deliberate attempt to misrepresent the offer, may be considered as sufficient basis to eliminate the violating party from consideration for future contract awards.

## **INTERPRETATION**

Interpretation of the wording of this document shall be the responsibility of PEI and that interpretation shall be final.

## **CONFIDENTIALITY**

From the date of issuance of the RFP until the Proposal Due Date, the Proposer must not make available or discuss its Proposal, or any part thereof, with any employee or agent of PEI. The Proposer is hereby advised that PEI shall strive to keep confidential any part of its Proposal or any material marked as confidential, proprietary, or trade secret, unless PEI is required to disclose such material in accordance with law or court order.

## **USE OF SUBCONTRACTORS**

The Proposal must clearly state whether the Proposer intends to use Subcontractors to provide any portion of the Solar Farm installation, operations and management described in this RFP. If the Proposer's response includes a description of portion(s) of the Solar Farm installation, operations and management that will be subcontracted, the names and addresses of potential Subcontractors and the expected payment each will receive under the Contract must be disclosed.

## **PROPOSER'S RESPONSIBILITY FOR SERVICES PROPOSED**

It is understood and the Proposer hereby agrees that it shall be solely responsible for all services they propose.

## **DISCLAIMER**

This RFP is a request for proposal only. All proposals will be treated as offers to enter into a contract with us. We reserve the right to reject any and all proposals, or portions thereof, and to request any additional information deemed necessary to supplement or clarify any such proposal. We further reserve the right to conduct negotiations concerning any and all aspects of each proposal or portion thereof. The acceptance of a proposal is subject to the execution of a written contract satisfactory to both parties.

## **BEST AND FINAL OFFER**

PEI reserves the right to request a best and final offer from the finalist respondent(s) if it deems such an approach necessary. In general, the best and final offer would consist of updated costs, as well as answers to specific questions that were identified during the evaluation of proposals. If PEI chooses to invoke this option, proposals would be re-evaluated by incorporating the information requested in the best and final offer document, including costs, and answers to specific questions presented in the document. The specific format for the best and final offer would be determined during evaluation discussions. Turnaround time for Proposers to respond to a best and final offer request will not exceed five (5) business days.

## **RIGHT TO INSPECT**

PEI reserves right to inspect and investigate thoroughly the establishment, facilities, financial reports and records, equipment, business reputation, environmental compliance, impact, safety and other qualifications of the Proposer and any proposed Subcontractors and to reject any Proposal irrespective of price if it shall be administratively determined that the Proposer is deficient in any of the essentials necessary to assure acceptable standards of performance. PEI reserves the right to continue this inspection procedure throughout the life of the Contract that may arise from this RFP.

## **EVALUATION AND AWARD OF CONTRACT**

### **ACCEPTANCE OF PROPOSALS**

PEI reserves the right to reject any or all Proposals or any part thereof, to waive informalities, and to accept the Proposal deemed most favorable to PEI.

### **EVALUATION OF PROPOSALS**

Proposals will be evaluated, based on the following criteria. PEI reserves the right to modify the criteria, which it considers to be in its best interest and in the best interest of the University of Illinois at Urbana-Champaign.

1. Overall quality and completeness of response, including:
  - a. Overall program plan for performing the required services, including at least a system that will deliver no less than 18,000 MWh ac / year, in the first full year of production.
  - b. Land Use Efficiency: maximizing production per acre of land needed for solar system
  - c. Compliance with the RFP specifications and university Facility Standards.
  - d. Proposed equipment quality and anticipated power production curves, with a preference for summer / late afternoon power.
2. Ability to perform the requested services, as reflected by:
  - a. Proposed personnel currently available to perform the requested services or demonstrated to be available at the time the requested services are required;
  - b. Technical training, education, and general experience;
  - c. Minority And Female-owned Business Enterprises (MAFBE) program information including estimated participation % of MAFBE subcontractors;
  - d. Specific experience in providing the requested services; and
  - e. Qualifications and abilities of personnel proposed to be assigned to perform the services
3. Qualifications of Proposers:
  - a. Financial Background: adequacy of financial resources
  - b. Corporate Structure (e.g., joint venture, subsidiary, partnership)
  - c. Number of years in market
  - d. Debt rating / credit rating/
  - e. Willingness to provide credit support (if needed)
  - f. References: favorable recommendations from referenced clients

4. Pricing:
  - a. \$ per MWh, scaled between highest and lowest
  - b. Buy-out Option availability
  - c. Donation Option availability
  - d. Termination Values

## **EVALUATION PROCESS**

All Proposals will be evaluated by an evaluation team. Based on this evaluation, PEI will determine the award of the Contract. PEI will award the Contract to the responsible proposer whose Proposal is determined to be the most beneficial to PEI, taking into consideration expertise, performance, completion, price and the evaluation factors set forth in this RFP. Completeness, clarity and conciseness of proposals will be a consideration in evaluating the responses.

## **PROPOSER PRESENTATIONS**

PEI reserves the right to, but is not obligated to request and require that any or all Proposers provide a formal presentation of its Proposal at a date and time to be determined mutually. If a presentation is required, it is anticipated that such presentation would not exceed three (3) hours. No Proposer will be entitled to be present during, or otherwise receive any information regarding any presentation of any other Proposer.

## **COMPETENCE AND QUALIFICATION**

PEI will award the Contract to the Proposer who has, in the opinion of PEI, best demonstrated competence and qualification for the type of product and service required at fair and reasonable prices and whose Proposal is deemed to be in the best interest of PEI. The contents of the proposal of the successful Proposer may become contractual obligations if a contract is accepted and signed by both parties. Failure of the successful Proposer to accept these obligations in a contract may result in cancellation of this award and such Proposer may be removed from future solicitations. Under these conditions, PEI reserves the right to award this RFP to the next ranking Proposer. PEI will demonstrate "good faith" in reaching a mutually acceptable contractual agreement. Notwithstanding this, there are certain conditions that are unacceptable to PEI.

Unacceptable conditions include, but are not limited to the following:

- Clauses requiring PEI to indemnify and hold harmless the successful respondent.
- Clauses that unduly restrict or place unacceptable claims of ownership on data which are the subject of the agreement/ contract.

- Clauses relating to requiring PEI to enter into reimbursement arrangements relative to attorney's fees.

## **SPECIFICATIONS OF PPA**

### **LOCATION**

Solar Farm 2.0 will be located on approximately 54 acres of University of Illinois Urbana-Champaign owned property. The property is located along the north side of Curtis Road/County Road 1300N, between First Street/County Road 1200E and US 45/Dunlap Street. If Proposer does not require the full area available, please indicate the amount of land needed. Placement of Solar Farm 2.0 should align with south edge of available site, maximizing efficiencies of remaining South Farm Research Areas.

The legal description of this full area, as noted on the **Appendix B: Plat of Survey/Topographic Survey**, is:

PART OF THE EAST HALF OF SECTION 25, TOWNSHIP 19 NORTH, RANGE 8 EAST OF THE THIRD P. M., LYING EAST OF THE EASTERLY RIGHT OF WAY LINE OF THE ILLINOIS CENTRAL RAILROAD, CHAMPAIGN COUNTY, ILLINOIS, DESCRIBED AS FOLLOWS:

COMMENCING AT THE SOUTHEAST CORNER OF SAID SECTION 25; THENCE N 00°21'05" W, ALONG THE EAST LINE OF SAID SECTION 25, A DISTANCE OF 180.02 FEET; THENCE N 89°28'01" W, 85.00 FEET TO THE POINT OF BEGINNING. THENCE CONTINUING FROM THE POINT OF BEGINNING, N 89°28'01" W, 2497.91 FEET; THENCE N 01°23'05" E, 65.69 FEET; THENCE N 88°45'31" W, 27.76 FEET TO THE EAST LINE OF A 150 FOOT EASEMENT PER DOC. 2014R04925; THENCE N 06°52'46" E ON SAID EAST LINE, 894.97 FEET; THENCE S 89°28'01" E, 2411.01 FEET TO A LINE PARALLEL AND 85.00 FEET WEST OF THE EAST LINE OF SAID SECTION 25; THENCE S 00°21'05" E, ALONG SAID PARALLEL LINE, A DISTANCE OF 917.19 FEET TO THE POINT OF BEGINNING.

CONTAINING 54.17 ACRES, MORE OR LESS.

See attached **Appendix B: Plat of Survey/Topographic Survey**, and image below.



## PHOTOVOLTAIC SYSTEM

At a minimum, the system shall consist of the supply and installation of a solar photovoltaic generation system, mounting structure, terminal and combiner box(es), quick-connect electrical connectors, conduit, DC wiring, DC disconnect, inverter(s), AC disconnect, AC wiring, all metering equipment, a system monitoring and data retrieval system, and all balance of system materials and equipment necessary to interconnect with the University's electrical distribution system.

- The Solar Farm must be able to deliver a minimum of 18,000 MWH / Yr. (verified in the first 12 full months of operation).
- The design of the Solar Farm must meet University Facility Standards, where applicable. Standards are listed at the Facilities & Services website under Facilities Standards: [www.FS.illinois.edu](http://www.FS.illinois.edu).
- All components shall have been designed to achieve optimum physical and performance compatibility and prototype tested to prove integrated design capability.
- The solar farm output as measured at the high-voltage bushings of the generator step-up transformer shall meet the IEEE 519-2014 Standards for harmonic content.

- All components of the solar farm project shall be designed to withstand hostile environment, including: water, ice, lightning, etc.
- Proposer must provide critical information and design review for interconnection approval to tie to University electrical grid. There is an existing university circuit near the solar farm site that may be connected to and utilized for up to 435 Amps at 13.8 KV AC. If peak loads exceed that value, a second circuit shall be provided by the proposer and the solar farm system must be configured to feed the University's Distribution Center #10 at 13.8 KV within the circuit amperage limits as outlined in **Appendix C: Utility Program Statement**.
- The Proposer shall provide all the associated electrical connections and equipment on the primary and secondary sides, based on National Electric Code (NEC), National Electric Safety Code (NESC) and IEEE Standard 1547 to step up the generated power and interconnect with the University's electrical distribution at 13,800 volts.
- Proposal shall include electrical connection to University power grid, including but not limited to any necessary protective relays, ancillary electrical equipment, circuit breakers and cables as noted in **Appendix C: Utility Program Statement**.
- Noise levels from the Solar Farm shall be in compliance with the applicable Illinois Pollution Control Board (*IPCB*) regulations (*35 Illinois Administrative Code Subtitle H: Noise Parts 900, 901, 910*). Some inverters may require special sound deadening construction to meet these requirements.
- Electrical inverters shall be located as far as possible from property lines and adjacent dwellings consistent with good engineering practice.
- Proposal shall include a revenue-grade meter that will be the determining factor for custody transfer, such as a Nexus 1272 meter or equivalent.
- During operation, the Proposer and PEI (the owner) shall give advance notification of planned outages and schedule them at a time of minimal interruption of service, but the proposal shall include an allowance for an average of 4 hours per year for forced outages.
- Project Security Fencing: A perimeter fence is required for the safety and security of the solar infrastructure. The Proposer shall install to the National Electric Safety Code, a permanent, grounded, six foot tall galvanized chain link fence with 3 strands of barbed wire on top, at a 45 degree angle, for a total height of seven feet around the perimeter of the Solar Farm 2.0. The fence enclosure will consist of the proper number of gates to code for vehicle, equipment and personnel access. Gates will be required to be secured by lock and key. There will be a two foot (2') wide perimeter around the outside base of the fence comprised of a CA1 rock boundary at a six inch depth and geotextile weed barrier.

Signage/placards will be secured to permanent fence at proper height and spacing according to local, state, county and industry code. The entire rock base of the fence shall be included in the leased area for the Solar Farm, such that the maintenance for the fence and rock perimeter, both inside and outside the fence, is the responsibility of the Proposer.

- Pollinator Habitat Installation: Within the fenced areas, the Proposer shall establish and maintain a pollinator friendly groundcover beneath the solar arrays, and in all other areas that are not paved for access roads or utility equipment pads. The groundcover shall consist of a seed mix of a minimum of three varieties of a turf type tall fescue, plus dutch white clover (*Trifolium repens*) and lanceleaf self-heal (*Prunella vulgaris* ssp. *Lanceolate*) and creeping thyme (*Thymus serpyllum*). Per 1000 square feet, seeding rate to be 4 lbs of tall fescue mix. Seeding rate for the perennial mix to be about 40 seeds per square foot.
- Solar panels with blue coloring are preferred.
- Drainage tiles are a vital aspect of University South Farm operations. If drain tiles are damaged during construction or operation of the Solar Farm 2.0, then the Proposer is fully responsible for restoring them to the pre-existing condition at their own expense.
- Fiber Optic Connection: The Proposer shall provide software for a remote computer system that is capable of monitoring and controlling the Solar Farm through the University's Delta V control system connected via fiber optic network system. Proposer will provide a fiber optic connection to the edge of the Solar Farm boundary, as noted in **Appendix C: Utility Program Statement**. The University will provide the fiber optic connection from the Solar Farm boundary to the University control center.

## EQUIPMENT AND SUPERVISION REQUIRED

The Proposer shall provide all items, articles, and operations listed, mentioned, and herein specified, including all tools, safety devices, supervision, and incidentals necessary to complete the solar installation, all safety equipment necessary to accomplish this project, including, but not limited to, safety harnesses, safety barriers, and warning signs. All of the equipment will be of new or first-rate condition.

## OPERATIONS AND MAINTENANCE

The Provider, at its own cost and expense, shall maintain the Site and System, including providing at its sole cost all spare and replacement parts for the system, site, fence, signage, security and grounds that are within the fence and boundary area.

Pollinator Habitat is required to maintain 85% coverage of the selected species of the specified plant diversity, within the fenced area, for the duration of the PPA.



Pollinator Habitat is expected to be mowed during the growing season a minimum of every 4 weeks and a maximum of every 2 weeks, dependent on weather and the needs for taller/invasive weed suppression. If mowing is not suppressing larger or invasive weeds (teasel, thistle, bindweed, etc.), non-selective herbicide may be selectively applied, as to reduce damage to intended plant species. Products shall be submitted for approval prior to use, with a preference for chemicals that do not drift through evaporation, or that infiltrate the groundwater system. Mowing height should be set at no less than 4 inches.

**ACCESS ROADS**

The Proposer shall provide appropriate access roads, as needed. The roads shall be installed to minimize disruption to the South Farms research fields, and to minimize impermeable surfaces. When possible, access roads should use existing access points rather than create new access points on the public roadways. The Village of Savoy owns Curtis Road adjacent to this site, Champaign Township owns First Street adjacent to this site, and any access roads must first be approved by the appropriate transportation jurisdiction. PEI requires the permanent access road to be from First Street.

The Proposer shall be responsible for all costs of transportation to the site and unloading the equipment. If the delivery may damage public roadways, the Proposer shall negotiate a Road Maintenance Agreement with the appropriate road commissioner. Following are the names and numbers of local and state highway departments:

Department Name	Contact	Comments
Champaign Township	217-352-0321 Keith Padgett Road Commissioner	Has jurisdiction over First Street from Windsor Road to Curtis Road
Village of Savoy	217-359-5894 Levi Kopmann Public Works Director	Has jurisdiction over Curtis Road from Neil Street to First Street

## PERMITTING

Proposer shall complete application and processing of all required permits, including but not limited to:

- Transportation permits, as needed.
- The Proposer will collaborate with Facilities & Services, Environmental Compliance Department, to prepare and submit any and all applicable environmental permit applications associated with project construction and operation.
- Illinois Department of Natural Resources' (IDNR) Ecological Compliance Assessment Tool, or EcoCAT, at <https://www.dnr.illinois.gov/programs/EcoCAT/Pages/default.aspx>.
- University approval of interconnection details.

## RENEWABLE ENERGY INCENTIVES

The selected Proposer shall prepare and submit all of the required incentive paperwork and reporting in support of any potential incentives available from the Federal government and State of Illinois energy programs/initiatives. The Proposer awarded the winning RFP bid, will be responsible for transferring the RECs to PEI using the Midwest Renewable Energy Tracking System (M-RETS).

## **REQUIRED SUBMITTALS**

The Proposer shall assemble a complete submittal package within 30 days of Award of Contract, for review and approval.

## SHOP DRAWINGS

Within 30 days of Award of Contract, the successful Proposer will be required to submit shop drawings for the complete Solar Farm System. Include detailed electrical plans, site plans, and detailed equipment catalog data for the power distribution, lighting, control, signals, communication systems. The shop drawings shall include detailed drawings for any applicable access roads, electrical equipment /structures, and fiber optic network connection.

- Solar photovoltaic system layout, design documents and ground plans, including seed mix
- System description including dimensions, type of installation, product data sheets, single line electrical diagram, structural engineer certification

- Material, equipment, and procedural information for installation of any required infrastructure for the interconnection to the University' electrical distribution system.
- Description of the anchorage structures showing details of how the system will be anchored
- System calculated annual electricity output
- A summary of all anticipated approvals that will be required for the proposed project
- Schematic and preliminary designs
- Project implementation and completion schedule
- Product description information
- Equipment details, descriptions, and specifications

Assemble shop drawings into one coordinated submittal. The drawings will be reviewed by University personnel for comments. Comments must be addressed prior to approval of interconnection to University electrical grid and approval to proceed with construction.

### PRE-JOB MEETING

At the time that the contract is awarded, a University representative shall contact the successful Proposer for the purpose of setting up a pre-job meeting. This meeting will take place a minimum of thirty days before the job is scheduled to begin. The purpose of this meeting is to inform the University of the Construction Schedule, on-going research to be aware of, where construction equipment and parts are to be stored, and any other pertinent information relating to the job.

### PREVAILING WAGE

The successful Proposer will be required to pay prevailing wages (hourly rate plus certain benefits), which can be found at <http://www.state.il.us/agency/idol/>.

### COORDINATION

- Parking: The Proposer shall make on-campus parking arrangements with the University Parking Department: 217-333-3530.
- South Farms Research: The Proposer shall work with the University designated representative, Allen Parrish (217-778-8730), to respect the existing research on-going in the South Farms area.
- Proposer shall collaborate with University to respond to inquiries from the public about the solar farm project.

## **PROPOSAL RESPONSE**

### **FORMAT OF PROPOSAL**

The Proposal will be submitted in (2) parts; the first (1<sup>st</sup>) part will consist of the **technical proposal** including all attachments and technical aspects requested in the RFP, the second (2<sup>nd</sup>) part will consist of the **pricing proposal** and will consist of any attachments and all price requested components of the RFP. The technical and price proposals must be **clearly marked** and **submitted individually**.

### **DELIVERY OF PROPOSAL PACKAGE**

The Proposals are to be emailed to PEI to the address shown on the cover sheet of this RFP. The Proposer remains solely responsible for insuring that its Proposal is received at the time, date, and place specified. PEI assumes no responsibility for any Proposal not so received, regardless of act or circumstance. Proposals received after the time specified in the RFP will not be considered.

### **PROPOSAL ORGANIZATION REQUIREMENTS**

To provide uniformity and to facilitate comparison of Proposals, **all information submitted must clearly refer to the section reference numbers in this RFP.** All information submitted must use the same organization of sections as listed below, in the same sequence as listed, and referring to the listed sections numbers. PEI reserves the right to waive minor variances or irregularities.

**Any material submitted in response to this RFP becomes the property of PEI upon delivery.**

## **Proposal Shall Include the Following Sections**

### **PART 1: TECHNICAL PROPOSAL**

#### **1.0 EXECUTIVE SUMMARY**

This should be a 1-2 page summary, with the following details:

- Name of Proposer
- Proposed site layout
- Proposed Max/Peak AC and DC power generation, and proposed annual generation in year one of operation
- Proposed Energy Generation profile, including detailed explanation of the supporting calculations
- Proposed timeline of design, construction, and agreement period

#### **1.1 PROGRAM PLAN**

The Proposer must provide a Program Plan to support its Proposal. This Program Plan should describe the programs, assumptions, commitments, and expectations of the Proposer in providing the services required by PEI. The Program Plan should also include reporting commitments and specific suggestions regarding communication, planning, and performance review.

The Program Plan must include a clear and complete explanation of how the proposed Solar System meets all the specifications required in this RFP. This includes, but is not limited to, the proposed site plan with roads and inverter locations, landscape installation and maintenance plans, proposed equipment quality, type of solar panels, type of proposed inverters, power production curves, and annual degradation rate of solar panels.

#### **1.2 COMPANY BACKGROUND**

Provide information regarding company background and structure, including years in business, volume of clients, number of employees, areas of expertise, and a list of relevant services the company provides. Company must be an existing legal entity and in good standing with all appropriate U.S. governmental and regulatory authorities.

### **1.3 CONTACT INFORMATION**

The name, address, telephone, fax number, and primary contact persons of the company. If applicable, the company's branch office addresses, telephone numbers, fax numbers, and contact persons, noting the branch office that would be used to provide the services outlined in this RFP.

### **1.4 QUALIFICATION INFORMATION**

Provide resumes and/or background information and experience of key management and operational staff who will be assigned to provide the services outlined in this RFP, including but not limited to:

- a. Technical training and education;
- b. Specific experience with services being requested;
- c. Qualifications and abilities to perform the services outlined in this RFP; and
- d. General experience.

### **1.5 REFERENCES**

Three (3) references of **CURRENT CLIENTS**, including:

- Company Name
- Address
- Telephone Number
- Primary Contact
- Email Address
- Service Provided

Three (3) references of **CLIENTS NOT RENEWED OR CANCELLED**, including:

- Company Name
- Address
- Telephone Number
- Primary Contact
- Email Address
- Service Provided

NOTE: By providing the above contact information, Proposer certifies that it is empowered to use the names of references it provides and agrees that PEI may contact these references.

## **1.6 EXISTING INSTALLATIONS**

Proposer must be able to show three (3) satisfactory solar installations larger than 5 MW, which have been in operation for a period of one year or more.

## **1.7 INFORMATIONAL OR TRAINING SESSIONS**

Provide a description of the informational or training sessions, if any, the Proposer will conduct for the PEI employees being directly affected by provision of energy commodities being requested.

## **1.8 CREDIT RATING AND FINANCIAL CONDITION**

Company needs to have a minimum credit rating of BBB- (Standard & Poor's) or Baa3 (Moody's) and a market capitalization of \$500 million. The Company can meet this requirement by providing a Parental Company Guaranty from a parent that has a minimum credit rating of BBB- (Standard & Poor's) or Baa3 (Moody's) and a market capitalization of \$500 million. Provide the company's annual report and audited financial statements for the most recent fiscal year, including Balance Sheet and Income Statement.

## **1.9 OTHER INFORMATION**

Provide any other information the Proposer believes is pertinent to demonstrating its qualifications to provide the energy commodities being requested.

## **PART 2: PRICING PROPOSAL**

### **2.0 PRICING INFORMATION FORM**

Complete **Appendix A: Pricing Information**, including:

- a. Pricing for Bid (1), Bid (2) and Bid (3) per each bid description.
- b. Provide a schedule of buyout options for years 6, 10, and 15.
- c. Indicate availability of donation options for years 6, 10, 15, and 20.
- d. Provide a schedule of termination values for each year of the term.

### **2.1 PRICING DETAILS**

Complete details on how the price per MWh was arrived at, including projected Engineering, Procurement, and Construction (EPC) costs, depreciation, investment tax credits, sale of Renewable Energy Certificates (RECs), operating revenue and costs, and projected profit.

## **2.2 NO ADDITIONAL COSTS**

All costs are required to be included in the PPA \$/MWh prices. Please confirm in writing in this section of your proposal that there are no additional costs to PEI.

## **2.3 PERIOD OF FIRM PROPOSAL**

Offers must be kept firm for acceptance for one hundred and twenty (120) days from the due date of the RFP. Proposals with acceptance periods of less than one hundred and twenty (120) days may be considered non-responsive. The Respondent may specify a longer period than indicated. If the Respondent indicates no time period for acceptance, the proposal will be considered firm for one hundred and twenty (120) days and thereafter until written notice to the contrary is received. PEI reserves the right to request price refreshes after the initial proposal period, and understands Respondent may increase or decrease the offer price as compared to its initial proposal based on price fluctuations.

## **2.4 PAYMENT TERMS**

PEI requests that payment terms comply closely with the following. Billing invoices should be supplied by the 5th business day of the month following delivery, with payment due fifteen (15) days from receipt of the invoice.

## **2.5 SAMPLE POWER PURCHASE AGREEMENT**

A sample Power Purchase Agreement (PPA) must be included with the Proposal, including all contract subparts, such as Attachments, Exhibits, or Transaction Confirmations.

## **PEI ADDRESS AND CONTACT INFORMATION**

University Office of Capital Programs, C/O PrairieLand Energy, Inc.

**Attn: Kevin Chalmers**  
807 South Wright St., Suite 340  
Champaign, Illinois 61820  
(217) 244-3678

[kchalmer@uillinois.edu](mailto:kchalmer@uillinois.edu)





## APPENDIX A: Pricing Information

### PRICING OF BIDS

PEI encourages creative pricing proposals. All proposals will be evaluated from the perspective of a budgeted amount and on the proposed date of delivery. Prices must be stated in 2019 U.S. dollars. Ownership and ability to retain or resell solar renewable energy credits (SREC's) are the subject of each of the three bid options requested in this RFP. Please provide each of the pricing options in the spaces provided below.

### TWENTY YEAR POWER PURCHASE AGREEMENT PRICING

**Bid 1** - Prairieland Energy Inc. will purchase each MWh of energy produced, and the Proposer may retain the environmental attributes (RECs) associated with each MWh produced at the on-site Solar Farm 2.0.

- Delivered Cost of 20-year PPA for Bid 1 \$\_\_\_\_\_ per megawatt-hour (MWh)
- Annual Energy Generation \_\_\_\_\_ MWh, in first full production year
- Total Proposal Cost per year \$\_\_\_\_\_, in year one

**Bid 2** - Prairieland Energy Inc. will purchase each MWh of energy produced, and the environmental attributes (RECs) associated with each MWh produced at the on-site Solar Farm 2.0.

- Delivered Cost of 20-year PPA for Bid 2 \$\_\_\_\_\_ per megawatt-hour (MWh)
- Annual Energy Generation \_\_\_\_\_ MWh, in first full production year
- Total Proposal Cost per year \$\_\_\_\_\_, in year one



**Bid 3** - Prairie Energy Inc. will purchase each MWh of energy produced. The Proposer may retain the environmental attributes (RECs) associated with each MWh produced at the on-site Solar Farm 2.0.

- Delivered Cost of 20-year PPA for Bid 3 \$\_\_\_\_\_ per megawatt-hour (MWh)
- Annual Energy Generation \_\_\_\_\_ MWh, in first full production year
- Total Proposal Cost per year \$\_\_\_\_\_, in year one

### TEN YEAR POWER PURCHASE AGREEMENT PRICING

**Bid 1** - Prairie Energy Inc. will purchase each MWh of energy produced, and the Proposer may retain the environmental attributes (RECs) associated with each MWh produced at the on-site Solar Farm 2.0.

- Delivered Cost of 10-year PPA for Bid 1 \$\_\_\_\_\_ per megawatt-hour (MWh)
- Annual Energy Generation \_\_\_\_\_ MWh, in first full production year
- Total Proposal Cost per year \$\_\_\_\_\_, in year one

**Bid 2** - Prairie Energy Inc. will purchase each MWh of energy produced, and the environmental attributes (RECs) associated with each MWh produced at the on-site Solar Farm 2.0.

- Delivered Cost of 10-year PPA for Bid 2 \$\_\_\_\_\_ per megawatt-hour (MWh)
- Annual Energy Generation \_\_\_\_\_ MWh, in first full production year
- Total Proposal Cost per year \$\_\_\_\_\_, in year one



**Bid 3** - PrairieLand Energy Inc. will purchase each MWh of energy produced. The Proposer may retain the environmental attributes (RECs) associated with each MWh produced at the on-site Solar Farm 2.0.

- Delivered Cost of 10-year PPA for Bid 3 \$\_\_\_\_\_per megawatt-hour (MWh)
- Annual Energy Generation \_\_\_\_\_ MWh, in first full production year
- Total Proposal Cost per year \$\_\_\_\_\_, in year one

PEI reserves the right to accept the option that the University considers to be in its best interest.

### **BUY-OUT OPTIONS**

PEI, on behalf of the University, reserves the sole right to Buy-Out this Contract for any or all of the option periods specified based on continuing need and favorable market conditions, when in the best interest of the University. PEI, on behalf of the University, reserves the right to exercise any of the buy-out options early or to exercise more than one option at a time.

The University desires an option to Buy-Out this contract at six, ten, or fifteen years, contingent upon continuing need and availability of funds. Indicate available buy-out options below.

\_\_\_\_\_ Buy-out option is available at end of year six (6).

\_\_\_\_\_ Buy-out option is available at end of year (10).

\_\_\_\_\_ Buy-out option is available at end of year fifteen (15).

\_\_\_\_\_ We do not offer a buy-out option.

### **DONATION OPTION AVAILABILITY**

PEI understands that some Proposers may elect to donate the Solar System during the PPA term, or at the end of the term. Indicate whether you plan to donate the system during any of the following times.



- \_\_\_\_\_ Donation option is available at end of year six (6).
- \_\_\_\_\_ Donation option is available at end of year (10).
- \_\_\_\_\_ Donation option is available at end of year fifteen (15).
- \_\_\_\_\_ Donation option is available at end of year twenty (20).
- \_\_\_\_\_ We do not offer a buy-out option.

### TERMINATION VALUES FOR TWENTY YEAR PPA

Contract year	Termination Value
1.	
2.	
3.	
4.	
5.	
6.	
7.	
8.	
9.	
10.	
11.	
12.	
13.	
14.	
15.	
16.	
17.	

18.	
19.	
20.	

**TERMINATION VALUES FOR TEN YEAR PPA**

<b>Contract year</b>	<b>Termination Value</b>
1.	
2.	
3.	
4.	
5.	
6.	
7.	
8.	
9.	
10.	

## **APPENDIX B: Plat of Survey/Topographic Survey**

(See PDF, pages C-1 to C-9)

# PLAT OF SURVEY/TOPOGRAPHIC SURVEY U18075 - SOLAR FARM 2.0

## JANUARY, 2019



**SITE KEY MAP**  
NOT TO SCALE

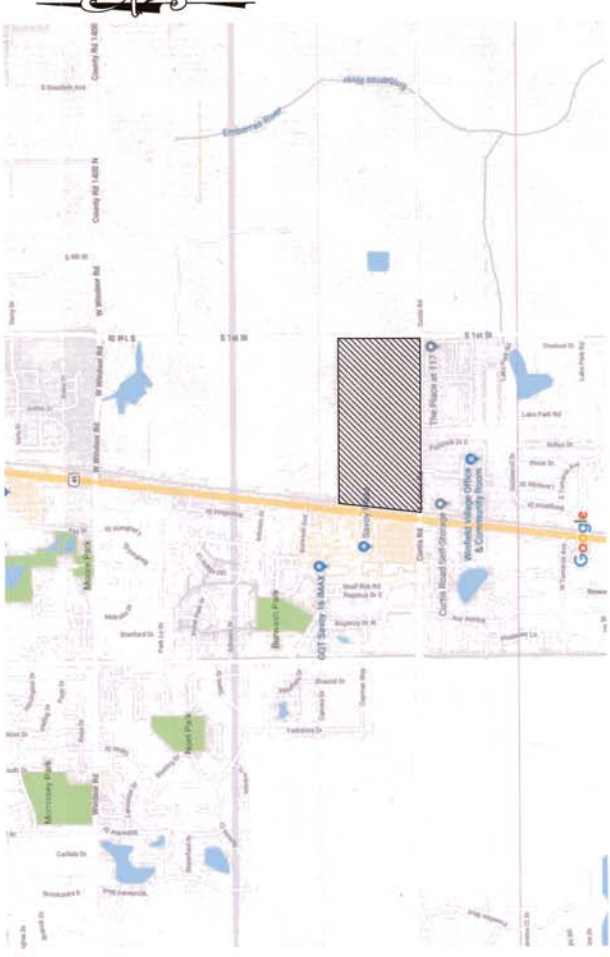

**SITE LOCATION MAP**  
NOT TO SCALE

### INDEX OF SHEETS

- C-1 COVER SHEET
- C-2 PLAT OF SURVEY
- C-3 TOPOGRAPHY
- C-4 TOPOGRAPHY AREA C-4
- C-5 TOPOGRAPHY AREA C-5
- C-6 TOPOGRAPHY AREA C-6
- C-7 TOPOGRAPHY AREA C-7
- C-8 TOPOGRAPHY AREA C-8
- C-9 TOPOGRAPHY AREA C-9

### LEGEND

- EX. GATE POST
- EX. ELECTRIC MANHOLE
- EX. ELECTRIC PEDASTEL
- EX. ELECTRIC MANHOLE
- EX. SANITARY MANHOLE
- EX. GAS MANHOLE
- EX. GAS VALVE
- EX. TELEPHONE MANHOLE
- EX. WATER VALVE
- EX. POWER POLE WITH TRANSFORMER
- EX. SIGN
- EX. GUY WIRE
- EX. POWER POLE
- EX. TELEPHONE PEDASTEL
- EX. HANDHOLE
- EX. FIRE HYDRANT
- EX. LIGHT POLE
- EX. FIBER SPLICE BOX
- EX. GAS LINE
- EX. SANITARY SEWER
- EX. UNDERGROUND ELECTRIC
- EX. OVERHEAD ELECTRIC
- EX. FENCE
- EX. FIBER OPTIC LINE
- EX. TELEPHONE LINE
- EX. WATER LINE
- EX. SIDEWALK
- EX. CROP LINE

### HORIZONTAL SITE CONTROL

P.T. NO.	NORTHING	EASTING
FEI #1	1239073.636	1008557.006 (IRON PIN) (SHEET C-4)
FEI #2	1239095.664	1010762.500 (IRON PIN) (SHEET C-6)

### BENCHMARKS:

- BM #1 - CAP BOLT ON FIRE HYDRANT IN MIDDLE OF WORD "MUELLER," ELEVATION = 621.68 (SHEET C-5)
- BM #2 - CAP BOLT ON FIRE HYDRANT IN MIDDLE OF WORD "MUELLER," ELEVATION = 618.31 (SHEET C-5)
- BM #3 - CAP BOLT ON FIRE HYDRANT IN MIDDLE OF WORD "MUELLER," ELEVATION = 617.30 (SHEET C-6)
- BM #4 - CAP BOLT ON FIRE HYDRANT IN MIDDLE OF WORD "MUELLER," ELEVATION = 614.31 (SHEET C-6)

NO PART OF THIS PLAT IS LOCATED WITHIN A SPECIAL FLOOD HAZARD AREA AS IDENTIFIED AS ZONE A BY THE FEDERAL EMERGENCY MANAGEMENT AGENCY FIRM #17019004280, EFFECTIVE DATE OCTOBER 2, 2013.

SURVEYOR HAS MADE NO INVESTIGATION OR INDEPENDENT SEARCH FOR EASEMENTS OF RECORD, ENCUMBRANCES, EGRESS FACILITIES, OWNERSHIP, TITLE SEARCH OR OTHER FACTS WHICH AN ACCURATE AND CURRENT TITLE SEARCH MAY DISCLOSE.

I, PETER B. WAGNER, HEREBY CERTIFY THAT I AM AN ILLINOIS PROFESSIONAL LAND SURVEYOR IN COMPLIANCE WITH THE LAWS OF THE STATE OF ILLINOIS AND THAT IN THE MONTH OF JANUARY, 2019, I MADE A SURVEY OF THE DESCRIBED PROPERTY AND THE FOREGOING PLAT REPRESENTS THE RESULTS OF SAID SURVEY.

Peter B. Wagner  
ILLINOIS PROFESSIONAL LAND SURVEYOR NO. 3660  
FUHRMANN ENGINEERING, INC.  
2852 SOUTH 11TH ST., SPRINGFIELD, IL 62703

LICENSE EXPIRATION DATE: 11/30/20  
THIS PROFESSIONAL SURVEY CONFORMS TO THE CURRENT ILLINOIS MINIMUM STANDARDS FOR A BOUNDARY SURVEY.  
FIRM REGISTRATION NO.: 184-003252  
FIELDWORK COMPLETION DATE: 12/20/2018



DATE: 1-30-19

COVER SHEET

C-1

2018-1375

**FUHRMANN ENGINEERING**  
2852 South 11th Street  
Springfield, Illinois 62703  
P: 217.529.5577  
Design Firm - 184 - 003252

UNIVERSITY OF ILLINOIS  
AT CHAMPAIGN - URBANA  
(U18075 - SOLAR FARM 2.0)  
CHAMPAIGN, IL



mk date issue

# PLAT OF SURVEY

PART OF THE EAST HALF OF SECTION 25, TOWNSHIP 19 NORTH, RANGE 8 EAST OF THE THIRD P.M., LYING EAST OF THE EASTERLY RIGHT OF WAY LINE OF THE ILLINOIS CENTRAL RAILROAD, CHAMPAIGN COUNTY, ILLINOIS.

## LEGAL DESCRIPTION

PART OF THE EAST HALF OF SECTION 25, TOWNSHIP 19 NORTH, RANGE 8 EAST OF THE THIRD P.M. LYING EAST OF THE EASTERLY RIGHT OF WAY LINE OF THE ILLINOIS CENTRAL RAILROAD, CHAMPAIGN COUNTY, ILLINOIS, DESCRIBED AS FOLLOWS:

COMMENCING AT THE SOUTHEAST CORNER OF SAID SECTION 25; THENCE N 00°21'05" W, ALONG THE EAST LINE OF SAID SECTION 25, A DISTANCE OF 180.02 FEET; THENCE N 89°28'01" W, 85.00 FEET TO THE POINT OF BEGINNING. THENCE CONTINUING FROM THE POINT OF BEGINNING, N 89°28'01" W, 2497.91 FEET; THENCE N 01°23'05" E, 65.69 FEET; THENCE N 88°45'31" W, 27.76 FEET TO THE EAST LINE OF A 150 FOOT EASEMENT PER DOC. 2014R04925; THENCE N 06°52'46" E ON SAID EAST LINE, 894.97 FEET; THENCE S 89°28'01" E, 2411.01 FEET TO A LINE PARALLEL AND 85.00 FEET WEST OF THE EAST LINE OF SAID SECTION 25; THENCE S 00°21'05" E, ALONG SAID PARALLEL LINE, A DISTANCE OF 917.19 FEET TO THE POINT OF BEGINNING.

CONTAINING 54.17 ACRES, MORE OR LESS.

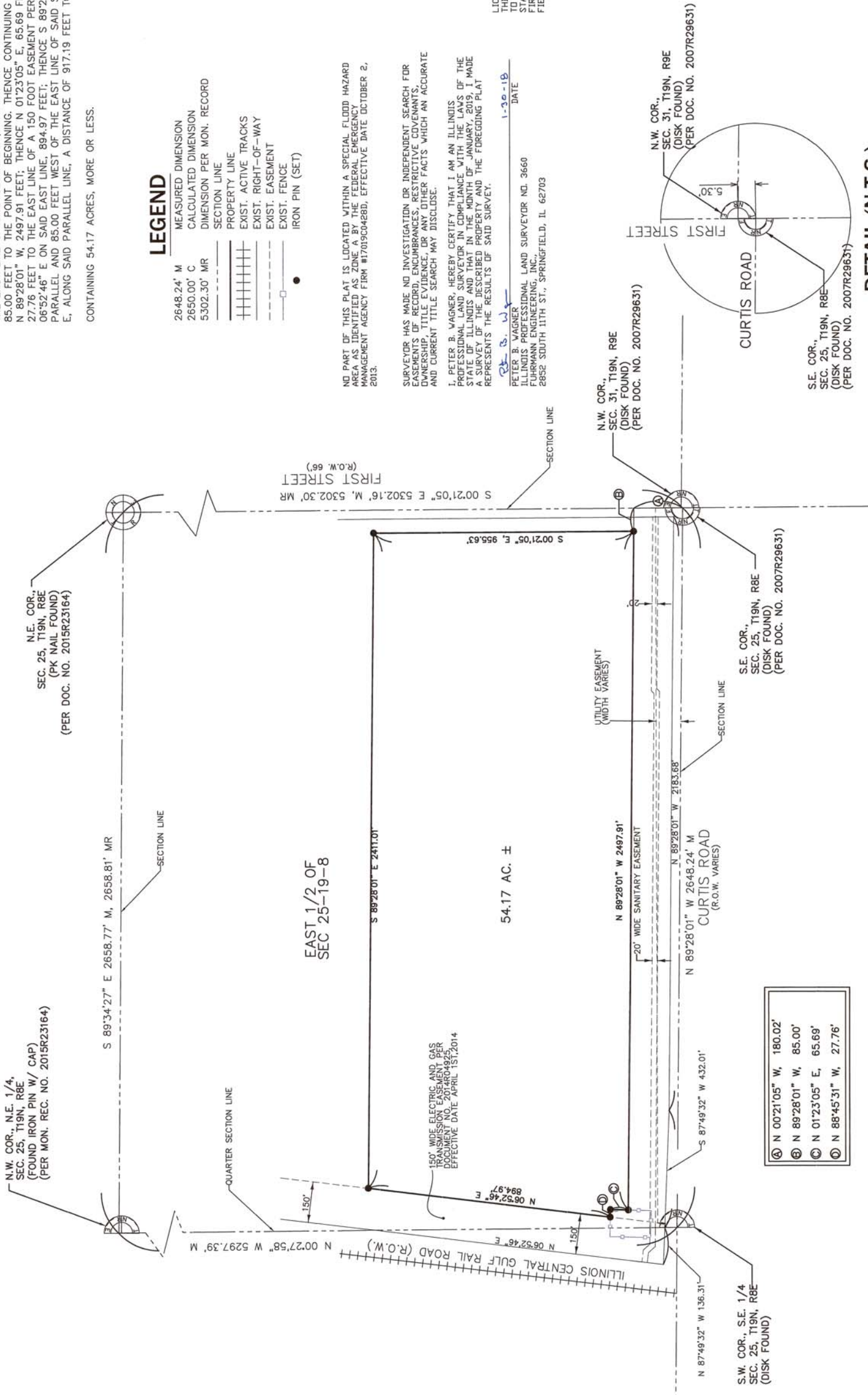

Ⓐ	N 00°21'05" W, 180.02'
Ⓑ	N 89°28'01" W, 85.00'
Ⓒ	N 01°23'05" E, 65.69'
Ⓓ	N 88°45'31" W, 27.76'

### LEGEND

2648.24' M	MEASURED DIMENSION
2650.00' C	CALCULATED DIMENSION
5302.30' MR	DIMENSION PER MON. RECORD
---	SECTION LINE
---	PROPERTY LINE
	EXIST. ACTIVE TRACKS
---	EXIST. RIGHT-OF-WAY
---	EXIST. EASEMENT
□	EXIST. FENCE
●	IRON PIN (SET)

NO PART OF THIS PLAT IS LOCATED WITHIN A SPECIAL FLOOD HAZARD AREA AS IDENTIFIED AS ZONE A BY THE FEDERAL EMERGENCY MANAGEMENT AGENCY FIRM #17019C0428D, EFFECTIVE DATE OCTOBER 2, 2013.

SURVEYOR HAS MADE NO INVESTIGATION OR INDEPENDENT SEARCH FOR EASEMENTS OF RECORD, ENCUMBRANCES, RESTRICTIVE COVENANTS, OWNERSHIP, TITLE EVIDENCE, OR ANY OTHER FACTS WHICH AN ACCURATE AND CURRENT TITLE SEARCH MAY DISCLOSE.

I, PETER B. WAGNER, HEREBY CERTIFY THAT I AM AN ILLINOIS PROFESSIONAL LAND SURVEYOR IN COMPLIANCE WITH THE LAWS OF THE STATE OF ILLINOIS AND THAT IN THE MONTH OF JANUARY, 2019, I MADE A SURVEY OF THE DESCRIBED PROPERTY AND THE FOREGOING PLAT REPRESENTS THE RESULTS OF SAID SURVEY.

PETER B. WAGNER  
ILLINOIS PROFESSIONAL LAND SURVEYOR NO. 3660  
FUHRMANN ENGINEERING, INC.  
2832 SOUTH 11TH ST., SPRINGFIELD, IL 62703



LICENSE EXPIRATION DATE: 11/30/20  
THIS PROFESSIONAL SURVEY CONFORMS TO THE CURRENT ILLINOIS MINIMUM STANDARDS FOR PROFESSIONAL SURVEY FIELDWORK COMPLETION DATE: 12/20/2018

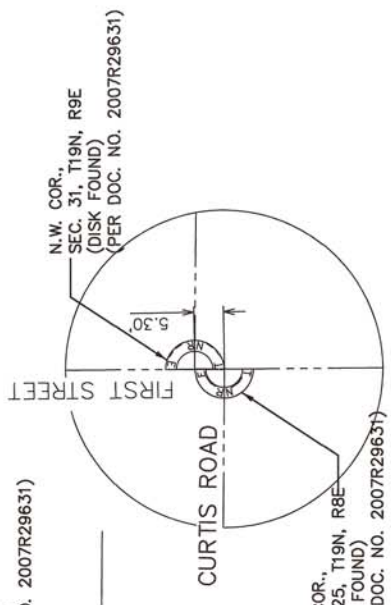

DETAIL (N.T.S.)



SCALE  
100' 0 200'

**FUHRMANN ENGINEERING**  
2832 South 11th Street  
Springfield, Illinois 62703  
P: 217.529.5577  
Design Firm - 184 - 003252

UNIVERSITY OF ILLINOIS  
AT CHAMPAIGN - URBANA  
(U18075 - SOLAR FARM 2.0)  
CHAMPAIGN, IL



mk	date	issue

PLAT OF SURVEY

C - 2

2018-1375



TOPOGRAPHY

mk	date	issue



UNIVERSITY OF ILLINOIS  
 AT CHAMPAIGN - URBANA  
 (U18075 - SOLAR FARM 2.0)  
 CHAMPAIGN, IL

**FUHRMANN**  
 ENGINEERING  
 2852 South 11th Street  
 Springfield, Illinois 62703  
 P: 217.529.5577  
 Design Firm - 184 - 003252



mk	date	issue



UNIVERSITY OF ILLINOIS  
AT CHAMPAIGN - URBANA  
(U18075 - SOLAR FARM 2.0)  
CHAMPAIGN, IL

**FUHRMANN**  
ENGINEERING  
2852 South 11th Street  
Springfield, Illinois 62703  
P: 217.529.5577  
Design Firm - 184 - 003252

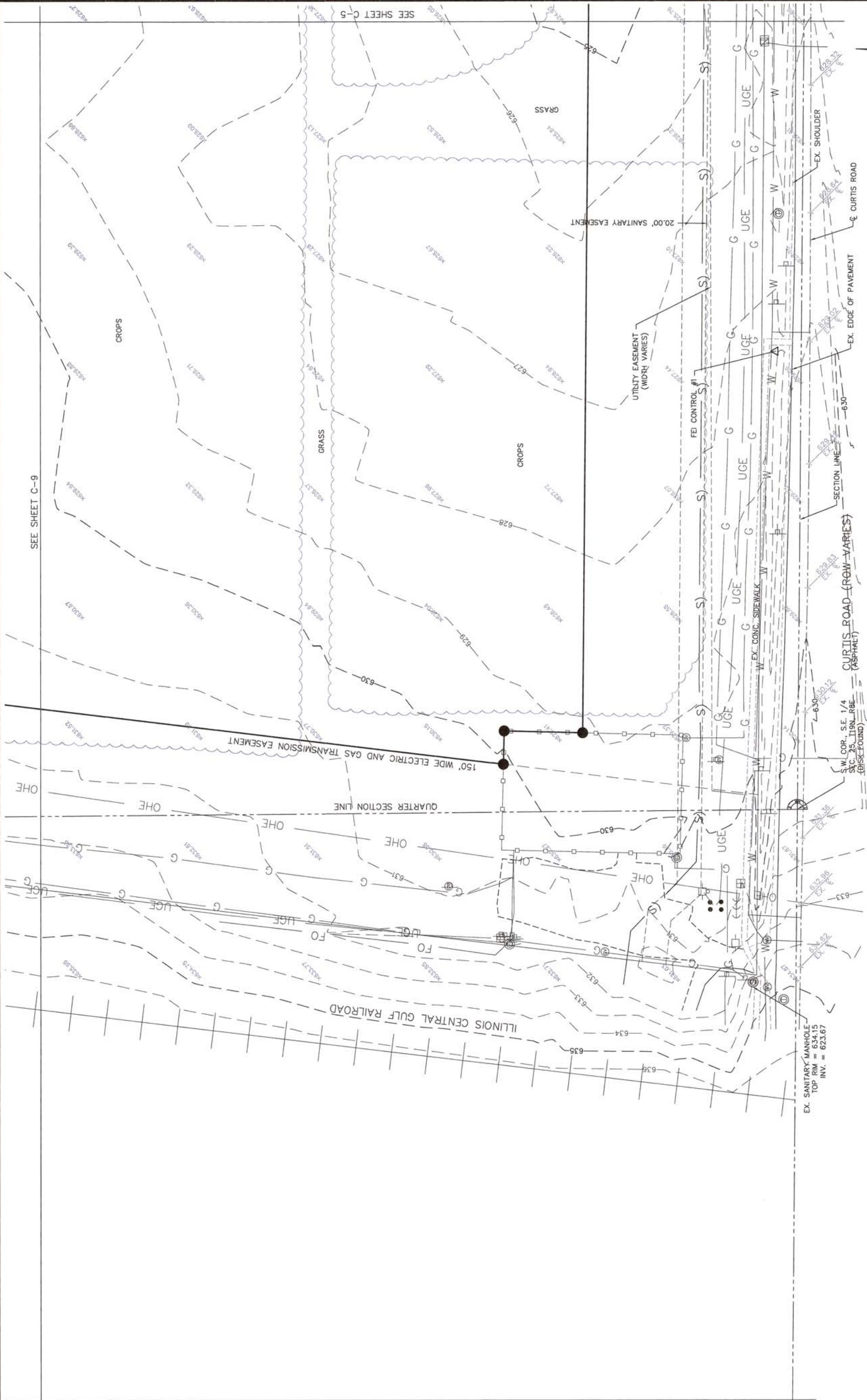

SEE SHEET C-9

SEE SHEET C-5

mk	date	issue



UNIVERSITY OF ILLINOIS  
AT CHAMPAIGN - URBANA  
(U18075 - SOLAR FARM 2.0)  
CHAMPAIGN, IL

**FUHRMANN**  
ENGINEERING  
2852 South 11th Street  
Springfield, Illinois 62703  
P: 217.529.5577  
Design Firm - 184 - 003252

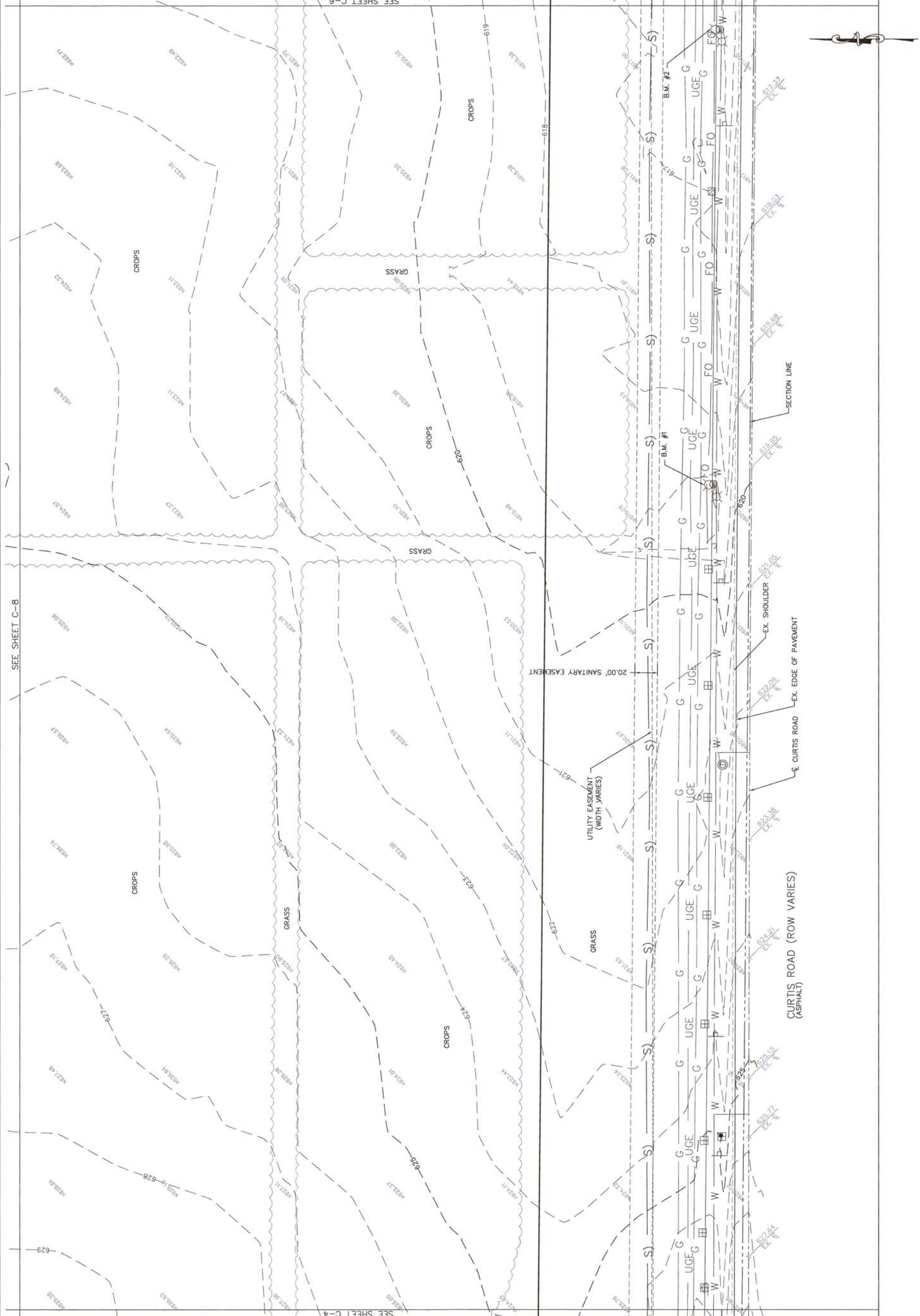

SEE SHEET C-6

SEE SHEET C-8

SEE SHEET C-4

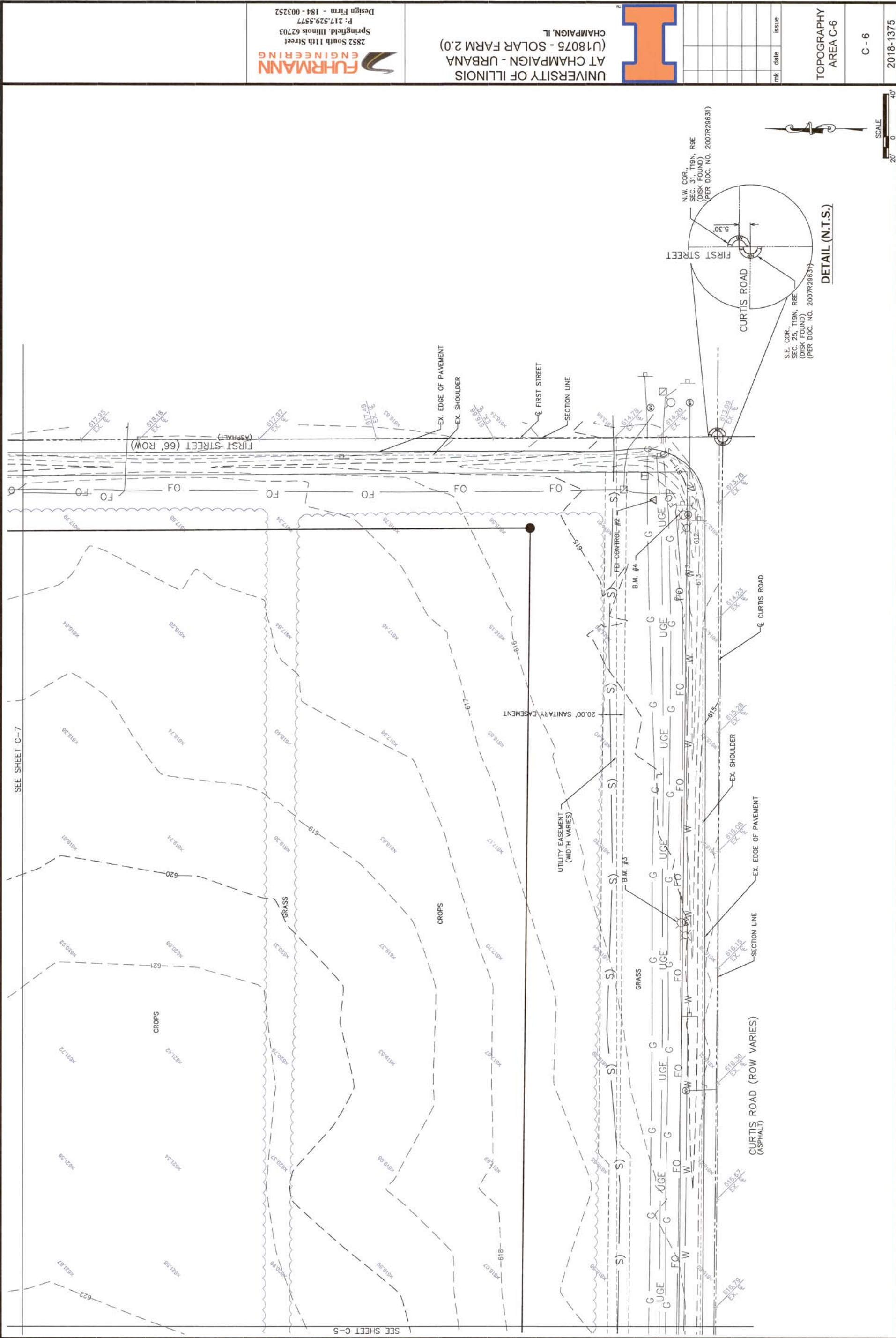

DETAIL (N.T.S.)



N.W. COR.,  
SEC. 31, T19N, R9E  
(DISK FOUND)  
(PER DOC. NO. 2007R29631)

S.E. COR.,  
SEC. 25, T19N, R9E  
(DISK FOUND)  
(PER DOC. NO. 2007R29631)

**FUHRMANN**  
ENGINEERING

2852 South 11th Street  
Springfield, Illinois 62703  
P: 217.529.5577  
Design Firm - 184 - 003252

UNIVERSITY OF ILLINOIS  
AT CHAMPAIGN - URBANA  
(U18075 - SOLAR FARM 2.0)  
CHAMPAIGN, IL



TOPOGRAPHY  
AREA C-6

C-6

2018-1375

SEE SHEET C-7

SEE SHEET C-5

mk	date	issue



UNIVERSITY OF ILLINOIS  
AT CHAMPAIGN - URBANA  
(U18075 - SOLAR FARM 2.0)  
CHAMPAIGN, IL

**FUHRMANN**  
ENGINEERING  
2852 South 11th Street  
Springfield, Illinois 62703  
P: 217.529.5577  
Design Firm - 184-003252

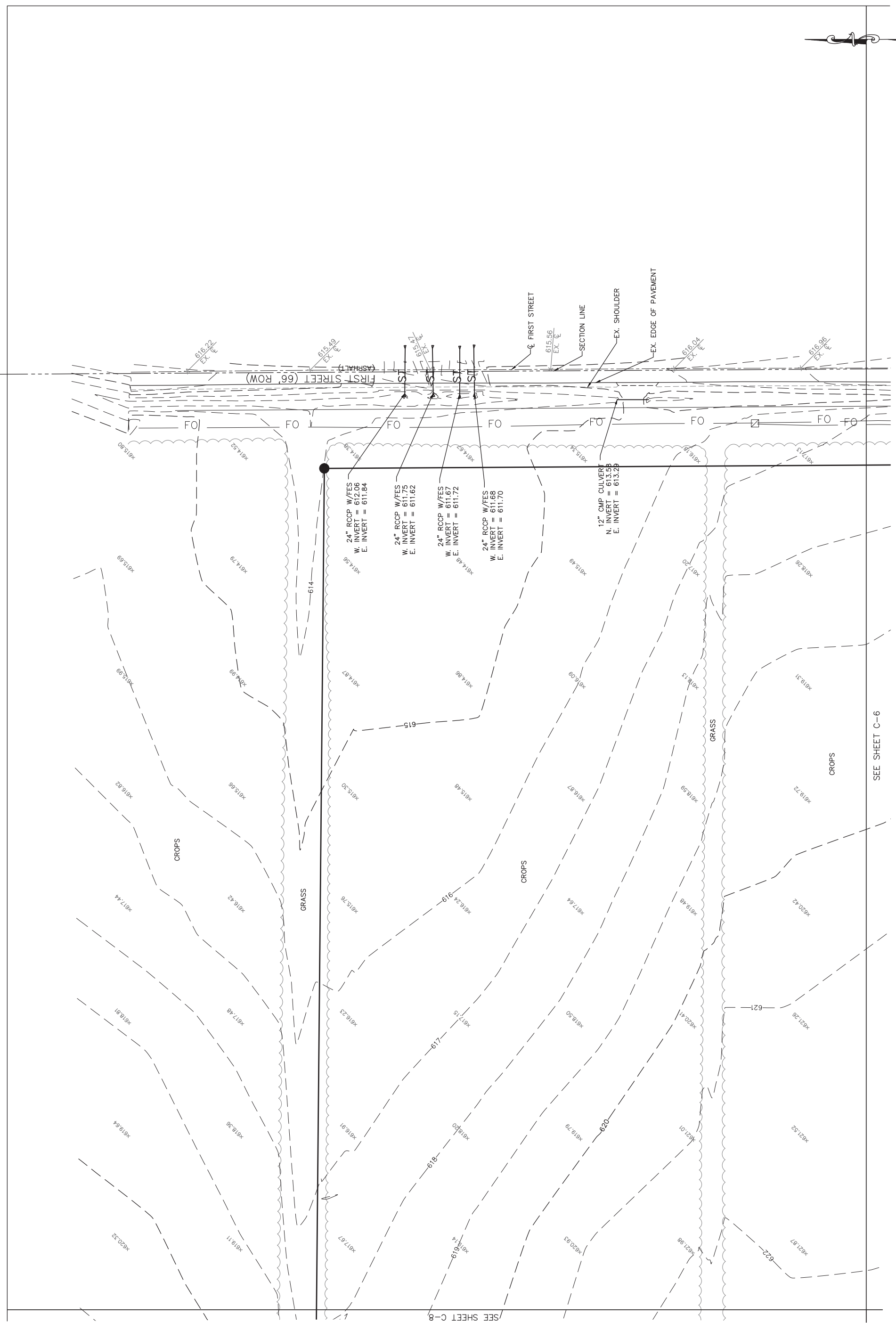

SEE SHEET C-6

SEE SHEET C-8

mk	date	issue



UNIVERSITY OF ILLINOIS  
AT CHAMPAIGN - URBANA  
(U18075 - SOLAR FARM 2.0)  
CHAMPAIGN, IL

**FUHRMANN**  
ENGINEERING  
2852 South 11th Street  
Springfield, Illinois 62703  
P: 217.529.5577  
Design Firm - 184 - 003252

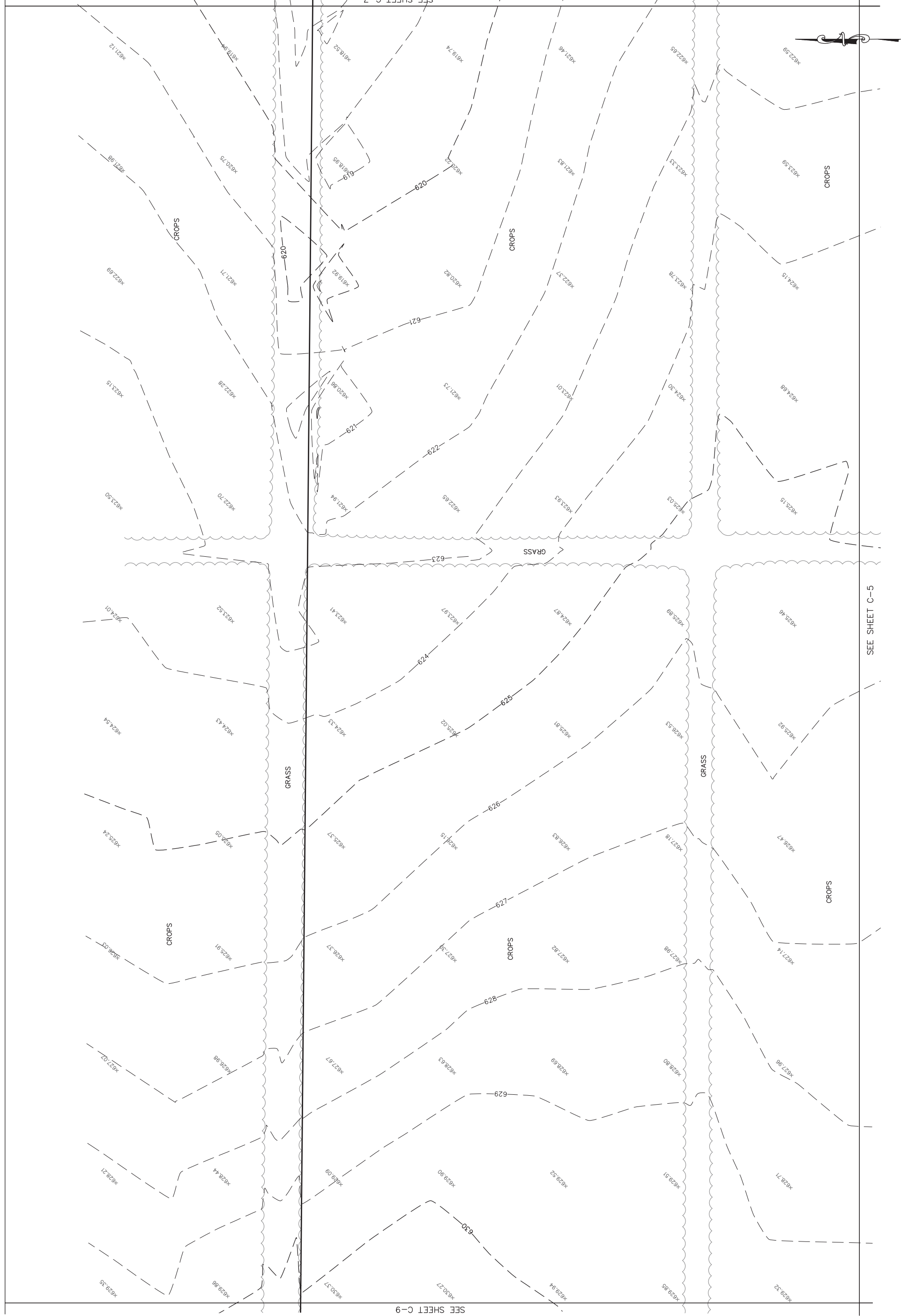

SEE SHEET C-7

SEE SHEET C-5

SEE SHEET C-9

mk	date	issue



UNIVERSITY OF ILLINOIS  
AT CHAMPAIGN - URBANA  
(U18075 - SOLAR FARM 2.0)  
CHAMPAIGN, IL

**FUHRMANN**  
ENGINEERING  
2852 South 11th Street  
Springfield, Illinois 62703  
P: 217.529.5577  
Design Firm - 184 - 003252

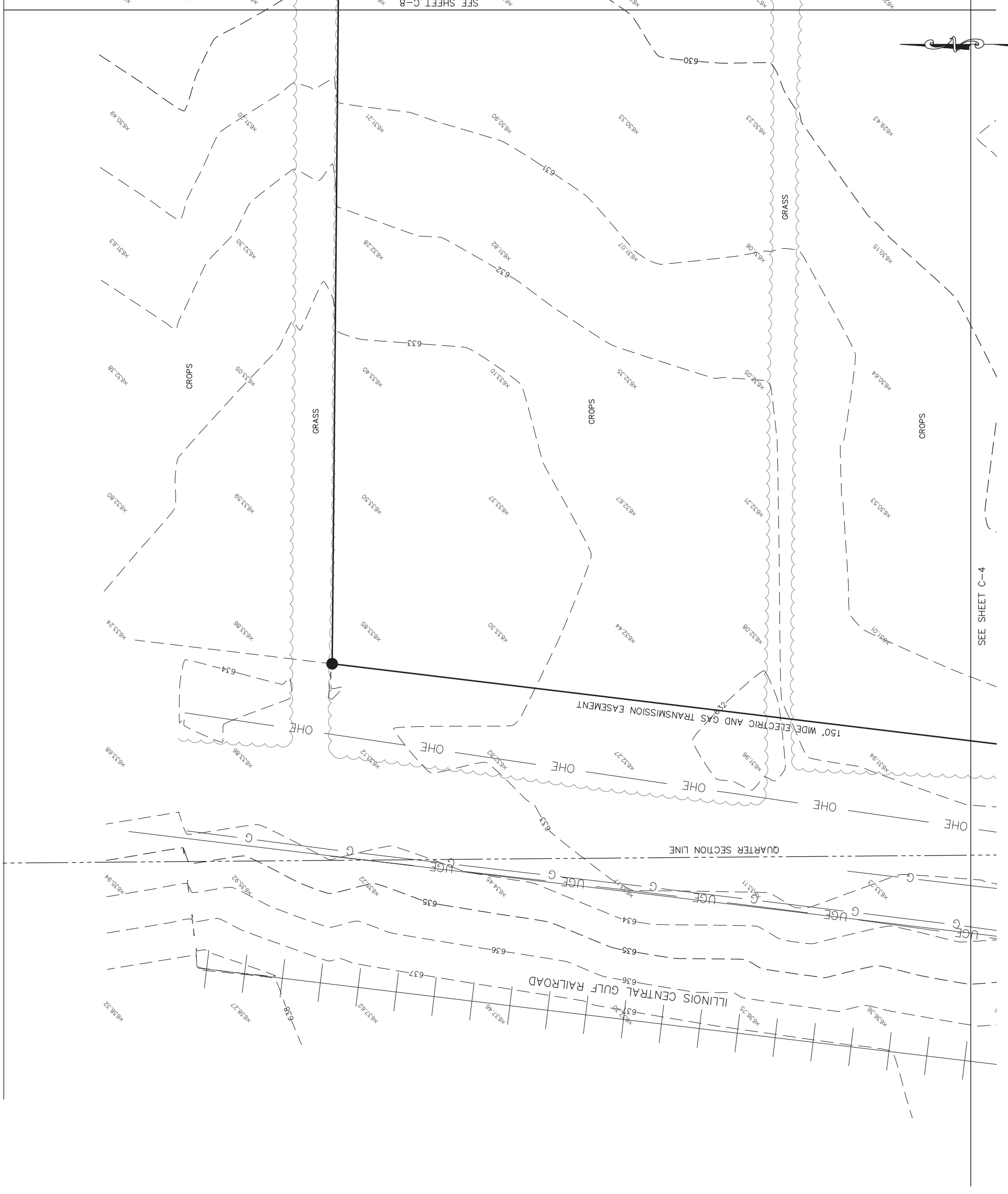

SEE SHEET C-8

SEE SHEET C-4

SEE SHEET C-8



## **APPENDIX C: Utility Program Statement**

TO: Solar Farm Proposers  
FROM: Robbie Bauer  
DATE: February 19, 2019  
SUBJECT: Solar Farm 2.0, Utility Program Statement

This document presents a conceptual utility program for estimating construction costs for the proposed Solar Farm 2.0. The intended use is for planning and conceptual design and is not a final design suitable for construction. These concepts are based on preliminary project information; therefore, it is likely that the utility program and construction costs will require revision as the project progresses to final design. We look forward to collaboration with the Design Team as the Project moves forward. An annotated site plan appears on the last page of this appendix.

Brief descriptions of the conceptual utility program for each utility service is provided below. The Proposer (also described here as Vendor) shall coordinate routing (including manhole details) with The University and submit detailed cable and termination information, routing drawings, and installation procedures with the shop drawing submittals:

Electrical Distribution: Vendor shall provide new 500 mcm 15 KV copper EPR cable (3 phase with ground) for the primary circuit from the solar farm system that shall terminate at the 600 Amp switch provided by the owner on the east side of First Street as shown. That existing 500 MCM circuit connects to The University's Electrical Distribution System at Distribution Center #10 (DC-10). This circuit may be utilized to provide a peak power output of 435 Amps AC at 13.8 KV to DC-10. If the solar farm is designed to provide peak power output in excess of that value, a second circuit shall be provided by the vendor from the Solar Farm to DC-10. If a second circuit is included, the solar farm shall be configured to provide power to DC-10 in a manner that divides the power to the two circuits as follows:

The second circuit provided by the vendor shall be a minimum of 2/0 copper 15 KV EPR cable circuit (3 phase with ground) from the solar farm system to an owner provided circuit breaker at DC-10. The vendor shall provide new underground conduit from MH 579 near First Street and Windsor Road to the solar farm site at the connection point of the solar farm. The new conduit portion shall include 3-way 15 KV 600 Amp Sectionalizing Cabinets such that no segment would exceed 1500 feet in cable length. At MH 579 the new circuit shall transition from the existing





## REQUEST FOR ON-SITE SOLAR FARM 2.0 AND PPA

UNIVERSITY OF ILLINOIS

---

duct bank to the new underground conduit to the solar farm site as shown in the UPS drawing. Voltage of both circuits shall be 13.8 kV and peak amperage of the circuit in the 2/0 cabling is to be approximately 196 amps less than (within 5%) the peak amperage of the 500 mcm cabling. The maximum current allowable of the 2/0 cabling is 210 amps. The vendor and the owner shall give advance notification of planned outages and schedule them at a time of minimal interruption of service, but the proposal shall include an allowance for an average of 4 hours per year for forced outages.

All electricity generated/used by this facility shall be metered (both directions) for both energy and demand. The meter must have a local display and the ability to communicate remotely via a Modbus TCP/IP network connection to the eDNA Data Historian operated by Utilities and Energy Services. A campus network data jack shall be located directly adjacent to the electric meter, that provides a static IP address for this meter. The manual readout shall be positioned at approximately five feet above the finished floor elevation.

Please keep us informed of subsequent scope changes that may impact utilities.

